



PHANTOM T1340

**FOUR-MEGAPIXEL
HIGH-SPEED CAMERA**

1 Mpx at over 12,130 fps
2048 x 1952 at over 3,270 fps
10Gb Ethernet & CineMag options

FEATURES & BENEFITS

IMAGE PERFORMANCE AND SENSITIVITY

- Custom 4 Mpx sensor incorporates CDS* for the ultimate in image quality, with low read noise to ensure data accuracy.
- The low noise floor combined with a native daylight ISO of 16,000 mono, 4,000 color, provides ability to resolve details in the shadows with less supplemental light.
- Binning combines pixels for increased frame rates and sensitivity at 1024 x 976 resolution and below – it’s like two cameras in one.

ULTIMATE WORKFLOW FLEXIBILITY

- 10Gb Ethernet allows for the fastest data connection and download directly from the camera’s RAM buffer.
- Supports Phantom CineMag V, up to 8TB, for even faster image transfer and direct recording for extended capture durations. Record for over an hour at 460 fps, HD resolution to an 8TB CineMag.
- On-camera controls and CineMag allows for complete standalone operation, eliminating the need for a computer. Offload later using 10Gb Ethernet from the camera body or dedicated CineStation IV.

*CDS = Correlated Double Sampling

FRAME RATES & EXPOSURE		
Top FPS at Max Resolution	3,270	
1 Megapixel FPS	9,900 fps Standard	12,130 fps Binned
Maximum FPS	113,510 at 640 x 16	
Minimum FPS	50	
CAR Increments	640 x 8	
Minimum Exposure	1 μ s Standard	499 ns with Fast Option* <i>(export controlled)</i>
Electronic Shutter	Global	
PIV Features	Shutter-off mode with straddle time of 437 ns, Supports Burst Mode	
Exposure Features	Auto-Exposure, Overexposure Indication over video and in PCC	

IMAGING		
Sensor Type	CMOS	
Maximum Resolution	2048 x 1952 Standard	1024 x 976 Binned
Bit Depth	12-bit	
Pixel Size	13.5 μ m Standard	27 μ m Binned
Sensor Size	27.6 x 26.3; 38mm Diagonal	
ISO Daylight (12232 STD)	Mono 16,000D; 25,000D Binned	Color 4,000D; 6,400D Binned
ISO Tungsten (12232 STD)	Mono 40,000T; 64,000T Binned	Color 5,000T; 6,400T Binned
Exposure Index	Mono 16,000–80,000	Color 4,000–20,000
Dynamic Range	61.4 dB Standard	62.0 dB Binned
Readout Noise	8.7 e- Standard	16.0 Binned

FRAME RATE CHART

Table provides examples of common resolutions and frame rates. The record times shown are for 72GB RAM at the frame rate shown. Duration will be ½ for 36GB and double for 144GB RAM.

Maximum Frame Rate - FPS; (72GB Record Time - Sec)		
Resolution (H x V)	Standard Mode	Binned Mode (Mono Output Only)
2048 x 1952	3,270 (3.8)	-
2048 x 1440	4,390 (3.9)	-
2048 x 1256	5,010 (3.9)	-
1920 x 1080	6,160 (3.9)	-
1280 x 720	13,050 (4.0)	-
1024 x 976	9,900 (5.0)	12,130 (4.1)
768 x 608	15,160 (7.1)	23,360 (4.6)
640 x 480	18,600 (8.0)	32,350 (5.0)
640 x 352	24,050 (9.0)	40,300 (5.4)
640 x 272	29,450 (9.0)	47,610 (6.0)
640 x 128	49,400 (11)	70,700 (8.3)
640 x 16	104,470 (35)	113,510 (32)
2048 x 8	107,900 (23)	-
640 x 8	113,510 (52)	-



CONNECTIVITY & SIGNALS	
Ethernet	Gigabit Standard, 10Gb Optional
Timecode	IRIG-B Modulated and Un-modulated
Port Descriptions	Fischer 8-pin Ethernet; Fischer 3-pin for Primary and Backup Power; Fischer 5-pin for Remote; Fischer 8-pin for Range Data; USB for WiFi Dongle; 3 Dedicated BNCs for Trigger, Timecode-in and SDI Video; 3 BNCs for Programmable I/O
I/O Signals	Programmable I/O (3 ports) for Fsync, Strobe, Ready, Timecode-out, Event, Pretrigger. Assign and define signals in PCC.
Hardware Trigger	Dedicated BNC
Software Trigger	Trigger button; via Ethernet; via Remote port; via Image-based auto trigger (IBAT)
Synchronization	External Sync via FSync or IRIG Timecode
Recording Features	Burst Mode; Image-based Auto Trigger, Auto-save to CineMag, Direct Recording to CineMag
Video Output	3G-SDI via BNC (rear), Din (front) and HDMI (front)
Accessory Power	4-pin Hirose (front) for 12V monitors up to 1 amp



CONTROL	
Software & OS	Phantom PCC (Windows); SDK also available with MatLab and LabView drivers
On-camera Controls	Standard Feature. Access menu system with encoder, viewed on video monitor. Buttons for trigger, play and save - Button color indicates current camera state.
Primary File Format	Phantom Cine RAW (.cine)
Alternative File Formats	Easily convert to formats including .mp4, Apple ProRes .mov, .avi, Tiff, JPG, DNG and many more using PCC. Cine files are directly compatible with several video editing and motion analysis programs.
Highlighted Software Features	Continuous Recording for automated workflows, Integrated Data Acquisition (NI-DAQ), support for DIC Calibration with Sync-Snapshot menu, advanced Image Tools including Crop & Resample, Tone Curves, Filters and more

MEMORY & STORAGE

RAM Buffer	36GB, 72GB, 144GB RAM Options
Multi-Cine	Up to 64 Partitions
Non-Volatile Media	Phantom CineMag V optional. Supports auto-save, direct record and video playback.
Direct Recording at 2048 x 1952	2TB CineMag V = 220 fps 8TB CineMag V = 240 fps

MECHANICAL

Housing Variants	CineMag and Non-CineMag Compatible Variants
Size	5 x 5 x 8" (12.7 x 12.7 x 20.3 cm) <i>(Not including handle. Handle adds 2" (5 cm) to height.)</i>
Weight	10 lbs (4.5 kg)
Lens Mounts	F-Mount standard (aperture support for Nikon G-style lenses). Also available: Canon EF (with electronic focus and iris control), PL, threaded C and universal M42 mounts
Mounting Points	Standard 1/4 x 20 and 3/8" mounting points on bottom (2 each). Remove handle and add cheese plate for top mounting. Vertical positioning bracket available.
Internal Shutter	Standard, for remote black references
Cooling	Active cooling. Quiet mode disables fans during capture.

GLOBAL SUPPORT NETWORK

The Phantom T-Series line is supported by Vision Research's Global Service and Support network, offering PhantomCare Performance Services from multiple sites around the globe. Maximize the value of your Phantom camera with a selection of professional services from which to choose.

Learn more about our service offering at www.phantomhighspeed.com/Service-Support

POWER

AC Power	100-240 VAC, 160W power supply included
Voltage Range	20-28V
Power Consumption	150W max with CineMag; 130W typical without CineMag
Battery Options	Works with 20-28V battery sources only, input through dedicated backup power port

ENVIRONMENTAL

Operating Temperature	-10–50°C
Storage Temperature	-20–70°C
Operational Shock	30G, 11msec sawtooth, 3 axes, 2 directions per axis, 10 shocks per direction (60 pulses total)
Regulatory	CE Emissions—CE Compliant EN 61326-1, Class A CE Immunity—CE Compliant EN 61326-1, Class A FCC—CFR 47, Part 15, Subpart B & ICES-003, Class A KC Emissions—KC Compliant KN32 KC Immunity—KC Compliant KN35 Safety—IEC 60950-1 (2012)

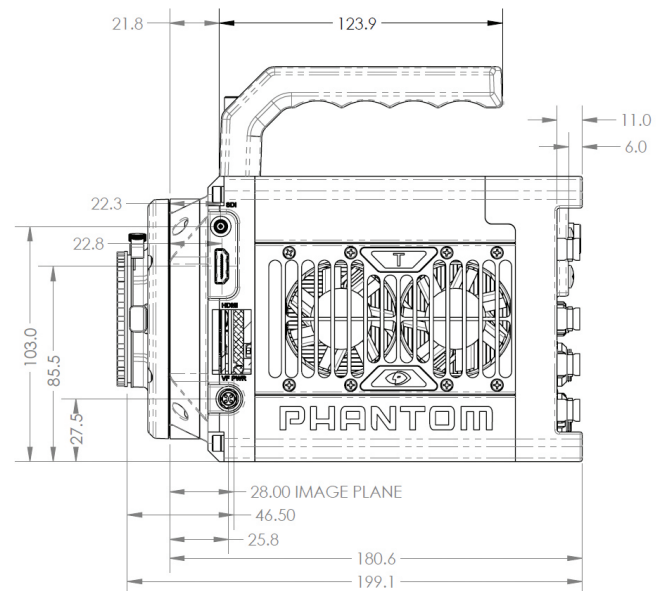

PARTNER INFO

ABOUT VISION RESEARCH

Focused. Since 1950, Vision Research has been designing, and manufacturing high-speed cameras. Our single focus is to invent, build, and support the most advanced cameras possible.

ViSiON
RESEARCH

AMETEK[®]
MATERIALS ANALYSIS DIVISION

100 Dey Road
Wayne, NJ 07470 USA
+1.973.696.4500